

## 'SolarPump' - Solar Powered Water Pumping

"Water Where and When You Need It"

- Livestock watering
- Irrigation
- Water for domestic consumption
- Pumping from bore holes, rivers and lagoons
- Pond & Lake management

Our solar powered water pumping systems can pump significant quantities of water from as far down as 100m. They use electrical power from solar photovoltaic panels (PV) to drive sophisticated and robust submersible water pumps.

### 'SolarPump' - Self-Install Kits

Our self install SolarPump kits provide you with a professionally designed and robust system to solve your water pumping needs. We complete all the wiring between the controller and the junction box and a waterproof splice between the power cable and the pump. So, all the complex installation work is done for you. No special tools are required and installation takes less than a day.

We have 3 'SolarPump Kits' covering a wide range of daily pumping volumes and depths.

SolarPump PS150 - For pumping from 1m to 5m

SolarPump PS200 - For pumping from 5m to 30m

SolarPump PS600 - For pumping from 30m+

Once installed, the system is totally automatic with a low water sensor stopping the pump should the water level drop. With only one moving part (the pump rotor) the system is very reliable. Pump and controller come with a 2-year manufacturer guarantee and the solar PV panels have a 20-year performance guarantee.

4 Elements Limited, The Old Dairy, North Weston, Thame, Oxon, OX9 2HA

Tel: 01844 210960 or Fax 01844 217844

E-mail: sales@4elements-uk.com Web: www.4elements-uk.com

## 'SolarPump' - PS150 Kit

The PS150 SolarPump Kit is designed to pump significant quantities of water up a 1m - 5m pumping head. The kit:

- Requires no external power
- Comes with a robust submersible pump can be used vertically in a borehole or horizontally in a spring or river
- Has no maintenance requirements
- Requires only concrete footings and plastic waterpipe to complete the system

### PS150 Kit Specification:

- 2 x 50W solar PV panels
- Solar panel cabling
- Pre-wired submersible pump
- 20m waterproof power cable
- Pre-wired low water sensor
- 20m of waterproof low water sensor cable
- Pre-wired pump controller
- Pre-wired junction box
- Galvanised steel pole mount
- Weather proof connecting cables
- Earthing rod cabling & connector
- 20m of security rope
- Concrete footings template & mounting bolts
- Full installation manual

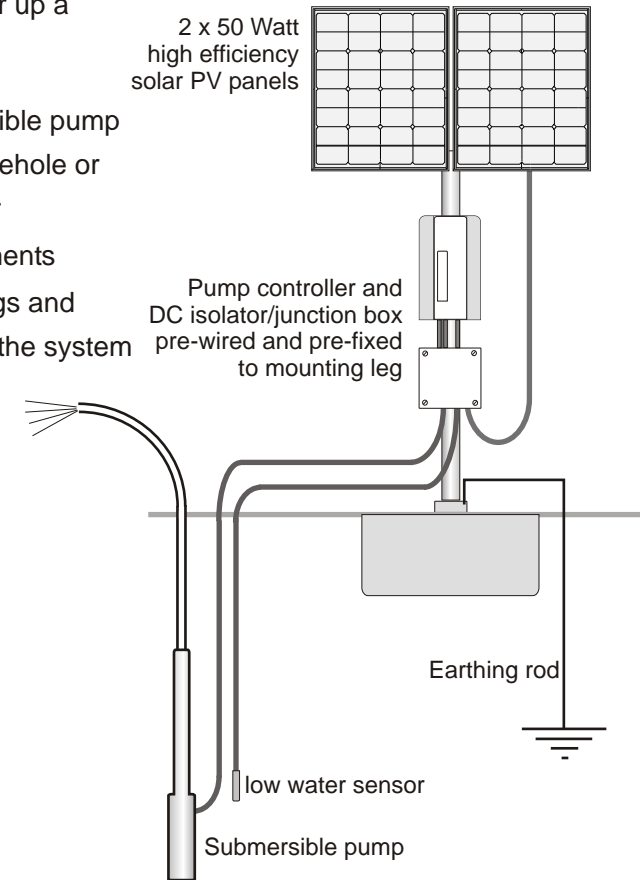

### PS150 Kit Pumping Performance

Mediterranean Latitude - Sunshine 6 hr/day

Head m	2	3	4	5
000's litres/day	18	17	15	12

## 'SolarPump' - PS200 Kit

The PS200 SolarPump Kit is designed to pump significant quantities of water up a 5m - 30m pumping head. The kit:

- Requires no external power
- Comes with a robust submersible pump can be used vertically in a borehole or horizontally in a spring or river
- Has no maintenance requirements
- Requires only concrete footings and plastic waterpipe to complete the system

### PS200 Kit Specification:

- 2 x 80W solar PV panels
- Solar panel cabling
- Pre-wired submersible pump
- 35m waterproof power cable
- Pre-wired low water sensor
- 35m of waterproof low water sensor cable
- Pre-wired pump controller
- Pre-wired junction box
- Galvanised steel pole mount
- Weather proof connecting cables
- Earthing rod cabling & connector
- 100m of security rope
- Concrete footings template & mounting bolts
- Full installation manual

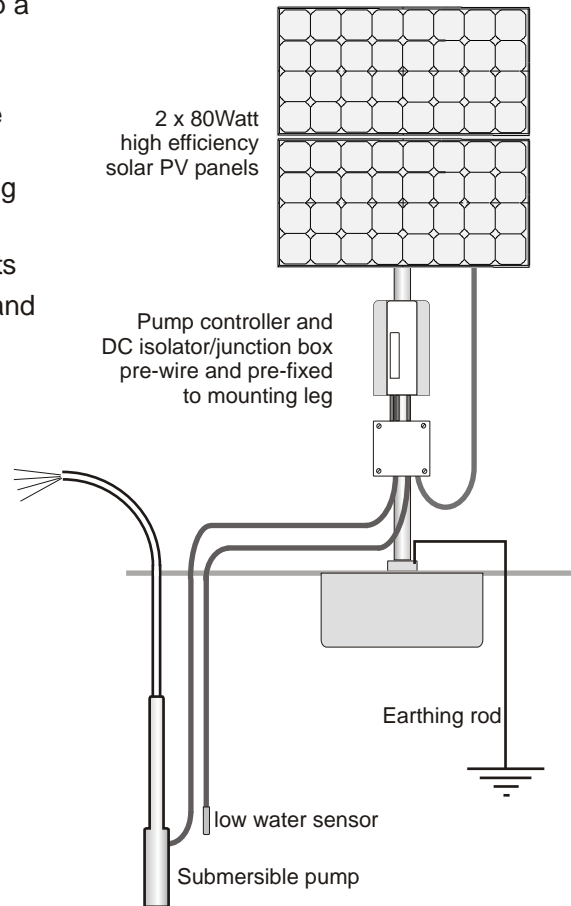

**PS200 Kit Pumping Performance  
Mediterranean Latitude - Sunshine 6 hr/day**

Head m	5	10	20	30
000's litres/day	13	11	7	4

## 'SolarPump' - PS600 Kit

The PS600 SolarPump Kit is designed to pump significant quantities of water up a 30m+ pumping head. The kit:

- Requires no external power
- Comes with a robust submersible pump can be used vertically in a borehole or horizontally in a spring or river
- Has no maintenance requirements
- Requires only concrete footings and plastic waterpipe to complete the system

### PS600 Kit Specification:

- 3 x 130W solar PV panels
- Solar panel cabling
- Pre-wired submersible pump
- 50m waterproof power cable
- Pre-wired low water sensor
- 50m of waterproof low water sensor cable
- Pre-wired pump controller
- Pre-wired junction box
- Galvanised steel pole mount
- Weather proof connecting cables
- Earthing rod cabling & connector
- 100m of security rope
- Concrete footings template & mounting bolts
- Full installation manual

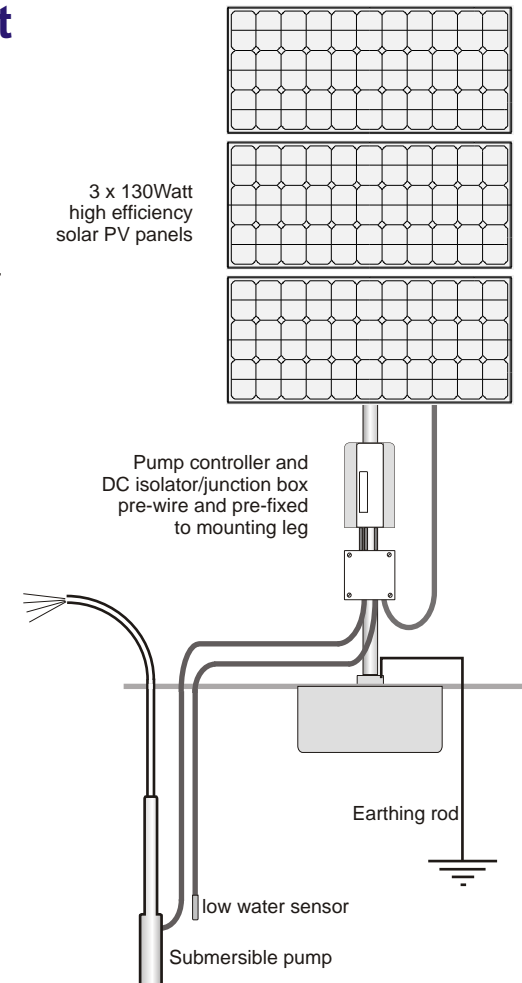

**PS600 Kit Pumping Performance  
Mediterranean Latitude - Sunshine 6 hr/day**

Head m	30	40	50
000's litres/day	9.5	6	5